

Microprocessor-based weight meter for materials

MS81046A



TECHNICAL DESCRIPTION AND INSTRUCTION FOR USAGE

PLOVDIV 2003

I. TECHNICAL DATA

1. Inputs

- 1) analog input from sensor for weight
 - linear current 0(4) ÷ 20 mA DC
 - linear voltage 0 ÷ 1(10) V DC
- 2) digital – start of dosing active 0 (0V)
- 3) digital 2 – selection of memorized parameters for dosing

2. Outputs

- 1) relay 250 V / up to 15 A*
 - K1 rough dosing
 - K2 fine dosing
 - K3 permission for emptying of the container
- 2) analog
 - Transmitting current 0 (4) ... 20 mA DC
 - Transmitting voltage 0 ... 1 (10) V DC

3. Display

4. Range of the display

6 digits LED 14 mm
- 99999 ÷ 99999***

5. Accuracy

±1 LSB

6. Keypad

Four membrane keys

7. Overall dimensions (W×H×L)

96×48×128 mm

8. Installation

Panel in a hole 90×44 mm

9. Weight

max. 400 g

10. Power supplying voltage

220 V $\pm 10\%$

11. Frequency of the power supplying voltage

50 Hz (±1 Hz)

12. Operating temperature

0 ÷ 50 °C

13. Operating relative humidity

0 ÷ 80% RH

14. Storage temperature

-10 ÷ 70 °C

15. Storage relative humidity

0 ÷ 95% RH

* - for current over 6 A you have to select another terminals

** - or another value according to the order of the customer

*** - the formats are X.XXXX; XX.XXX; XXX.XX; XXXX.X; XXXXX

II. FRONT AND BACK PANEL

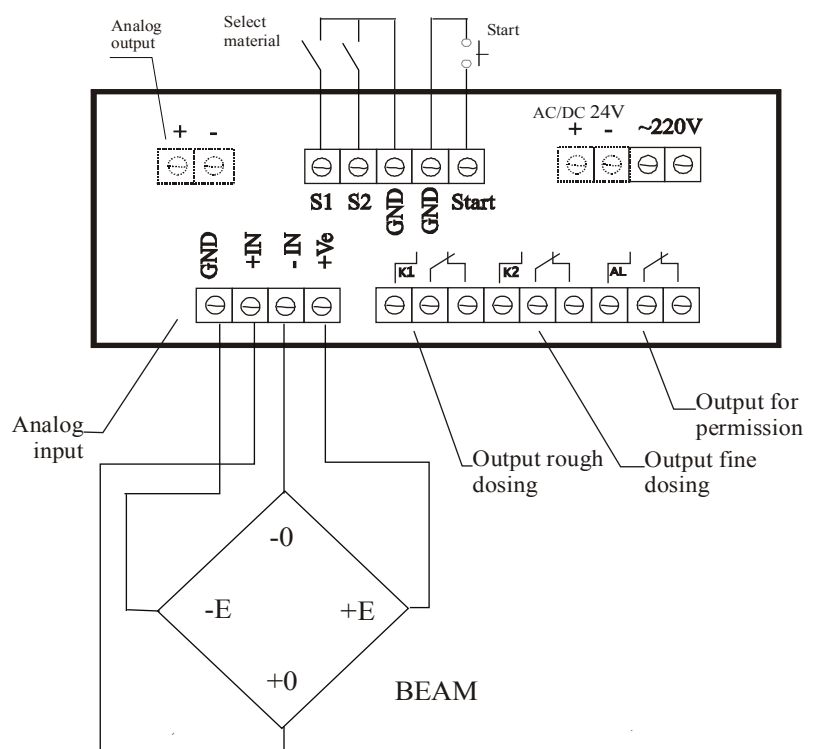
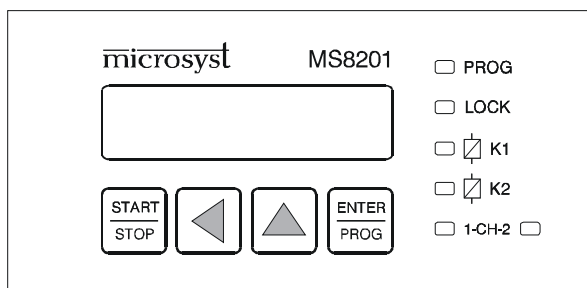

III. PRINCIPLE OPERATION OF THE WEIGHT METER

Before the start of the dosing by the inputs for selection of memorized parameters of dosing you can select the desired set of parameters, namely:

- Maximum admissible start weight “**StrtEn**”
- Weight of dosing “**doSE**”
- Weight of switching fast / slow dosing “**ChanGE**”
- Calibrating coefficient “**Corr**”.
- Maximum time of dosing “**tdoSE**”.
- Time for fixing of the weight under the maximum admissible one for a new start “**Strtdl**”

The controller supports from 1 to 4 sets of memorized parameters.

In operating mode “**TUNING OF PARAMETERS**” are tuned the parameters of this set, which is selected by the combination of the inputs for selection of set of parameters. In operating mode “**DOSING**” are used the parameters of this set, which is selected by the combination of the inputs for selection of set of parameters.

The controller indicates which set of parameters is selected to be current in menu “Prog”.

The controller has two types of operating modes.

In operating mode 0 at supplying of inner or outer start, the controller switches on the output for rough dosing. When reaching the programmed level, the output for rough dosing is switched off and the output for fine dosing is switched on. After the end of the dosing the output for fine dosing is switched off and the output for permission for emptying of the container is switched on. After the programmable time is up “**Strdl**” the output for permission for emptying of the container is switched off, too.

In operating mode 1 at supplying of inner or outer start, the controller switches on the output for permission and switches on the output for rough dosing. When reaching the programmed level, the output for rough dosing is switched off and the output for fine dosing is switched on. After the end of the dosing the output for fine dosing is switched off and you have to wait for emptying of the container. When the weight of the container is under the maximum admissible one for a new start “**StrEn**” for programmable time “**Strdl**”, the output for permission is switched off, too.

If the dosing is not realized for determined programmed time, all outputs are switched off and message about an error is displayed. New start is permitted only if the outer start had passed trough inactive level after the end of the dosing. *At switched on option “Automatic start” the controller is started again after the end of the last dosing without the necessity of an outer or inner start.*

IV. INSTRUCTIONS FOR USAGE

1. Screen menus and function of the buttons

Up	Change of the screen menus in the following order: <ul style="list-style-type: none"> - Zero – Displaying of the value of tare - Count – Number of the dosings - Call – Operating mode Calibration – they may be hidden - Prog – Tuning of the parameters - Measure – Current measured value <p>If you do not press any button for more than 5 seconds, you will pass to the main menu.</p>
Left	Pass to the main menu – Measure
Start/Stop	Start or stop the process of dosing. The operation of this button is determined according to the current status of the controller (operating mode measurement or operating mode dosing). <p>If you press it, the following inscription will be displayed:</p> <p>“Strt” – Start a process of dosing.</p> <p>“StOP” – Stop the process of dosing.</p> <p>“FuLL” - Impossible start of the process of dosing.</p> <ul style="list-style-type: none"> - The weight of the tare together with the weight for dosing exceeds the maximum weight, measured by the sensor. - In operating mode 1 – the container is not empty from the previous dosing (the measured weight is over the maximum admissible for start)

Enter/Prog	<p>According to the current selected menu this button has these functions:</p> <ol style="list-style-type: none"> 1. Measure – Taring of the instrument 2. Zero – Resetting of the current tare 3. Count – Resetting of the counter 4. Call – Enter operating mode calibration 5. Prog – Enter operating mode of tuning of parameters
------------	--

2. Calibration of the instrument

The calibration is realized as it follows:

1. Put a standard weight.
2. Wait for the indication to be fixed on the display.
3. Enter operating mode “CALIBRATION”.
4. By the pointers you can correct the displayed value according to the standard weight.
5. Press the button “Enter/Prog” to confirm.

Exit from operating mode “CALIBRATION” can also be realized automatically, if you do not press any button for 10 seconds, and the changed value is memorized.

3. Operating mode “TUNING OF PARAMETERS”

The tuning of the parameters – operating mode “Prog”. The change of the parameters is realized by the buttons “Left” and “Up”. The current digit for change is indicated by the symbol flashing point, and by the button “UP” you can change the value, and by the button “Left” you can change the position of the flashing point. If the change of the sign of the number is permitted, it is changed at position of the flashing point on the most left digit.

“doSE”	Weight of dosing. Dimension and decimal point according to the maximum measured weight and resolution of the sensor.
“ChAnGE”	Weight of switching from rough to fine dosing. Dimension and decimal point according to the weight of dosing.
“StrtEn”	Maximum admissible weight for a new start (remaining weight in the container after its emptying). This parameter can be seen only in oper. mode 1.
“Corr”	Correction , realized by the weight meter because of an error from the remaining weight, entering the container after switching off of the fine dosing and the error from the hesitation of the system. You have to consider, that the entered value for the correction is summed with the set-point for dosing, i.e. if the controller is dosing less than the set-point, this value has to be increased and if it is dosing more than the set-point – to be decreased.
“t dose”	Maximum time for dosing. If when this time is up the dosing has not ended, the process is stopped and flashing inscription “Error” appears. The inscription disappears at pressing of any button or a new start. At value of the parameter 0 the time is switched off, i.e. there is no limit for the time of dosing. Dimension -> 0... 120 Sec.
“Strtdl”	In operating mode 1 – the time for fixing of the weight under the minimum admissible weight for a new start. A new start is permitted only if the weight in the container has been under the minimum admissible one during this period of time. It is supervised only to the end of the dosing. In operating mode 0 – time for emptying of the container A new start is permitted after the time is up after the end of the dosing. Dimension -> 0.0... 20.0 Sec.

After the tuning of the last parameter inscription “End” is displayed. At pressing of a button different from “Enter/Prog” you will pass to second tuning of the parameters from the beginning. By pressing of the button “Enter/Prog” you can exit the operating mode of tuning.

4. LEDs

The controller has four LEDs - **K1**, **K2**, **LOCK** and **PROG**. The LEDs **K1** and **K2** are emitting light at switched on respectively outputs for rough and fine dosing, the LED **PROG** is emitting light in operating mode programming of the parameters of the controller. The LED **LOCK** is emitting light in the following cases:

- a) The controller is in process of dosing.
- b) Ended dosing, but the weight in the container is over the maximum admissible for a new start in operating mode 1.

5. Messages about errors

The controller displays the following messages about errors:

A) “**ErrorA**” – error at measurement. It is necessary the connection of the measuring beam with the instrument to be checked.

B) “**ErrorT**” – the maximum time for dosing is up. The inscription is flashing and alternating with the value of the current weight. The error can be deleted by pressing of any button or a new start.

C) “**ErrorU**” – the weight of the tare together with the set-pointed value of the weight for dosing exceed the maximum weight measured by the sensor.

V. OTHER POSSIBILITIES OF THE CONTROLLER

The controller realizes the automatic reading of the number of realized dosings and memorizes them in power-independent memory. As ended dosing is considered this dosing, which had ended in normal way, i.e. without pressing the button **Start/Stop** or after the time for dosing is up.

VI. SYSTEM PARAMETERS OF THE CONTROLLER, ACCESSIBLE AT PRESSED BUTTON **Enter/Prog** AT SWITCHING ON OF THE POWER SUPPLY TILL THE APPEARANCE OF INSCRIPTION “**Tune**”.

“ A1 ”	Multiplied coefficient for linearization of the sensor. (It is calculated automatically in operating mode of calibration) Dimension - ± 99999 (1024^i)
“ A0 ”	Free member for linearization of the sensor. Dimension - ± 99999
“ Point ”	Position of the decimal point – the senior 4 bits are read, i.e. admissible values 128, 64, 32, 16 and 0 for 0.0000, 00.000, 000.00, 000.0 and 00000
“ Hi L-t ”	Maximum measured weight by the sensor.
“ Filt D ”	Coefficient of the filter of the display. Dimension - 0... 1.00
“ Filt J ”	Filter jump for resetting of the display. Dimension - 0... 99999
“ tStArt ”	Time delay at automatic start for fixing of the system. Dimension: 0... 2.00 sec.
“ t On ”	Time, during which indications are not read, it starts after the activation of the process of dosing. During this time the output for rough dosing is switched on. Dimension: 0... 20.0 sec.
“ ConFiG ”	Configuring word. <i>For tuning see below.</i> Dimension: 0... 127
“ t End ”	Time, which you have to wait for after the end of the dosing for realization of automatic correction. At value 0 such correction will not be realized (it is not permitted).* Dimension: 0 .. 20.0 sec.

“d Zone”	Dead zone for automatic correction. Admittance of deviation from the set-pointed dose, in which a new value of the correction is not calculated. This parameter is visible only if the automatic correction is permitted. The dimension is according to the format of the display.
“Flt Ar”**	Arithmetic filter of the measured weight. Dimension: 1 .. 5
“Flt EP”***	Exponential filter of the measured weight. Dimension: 1 .. 5
“Flt J”	Filter jump for clearing in % of the range. Dimension: 0.1 .. 100.0
“Flt t”	Time for jump of the filter. Dimension: 0.00 .. 2.00 sec.
Hi nEt	Weight, corresponding to the higher limit of the range of the analog output. $A_{out} = (AP1 \cdot \frac{W}{Hi\ nEt} + AP0) \cdot 16$ {W – current indication, Aout – value of the input of DAC} Dimension: 0 .. 99999
AP1	Multiplying coefficient of the analog output Dimension: -99999 .. 99999
AP0	Coefficient “deviation” at the formation of A out Dimension: -99999 .. 99999

* At selected operating mode for automatic correction you have to wait programmable time “t End” after the end of the dosing, after which the dosed weight is read again and a calculation for automatic correction in the next doses, i.e. the value the parameter “Corr” is corrected. *At switching off of the power supply of the instrument this value is not memorized.*

** The values of the parameter correspond to the following arithmetic sums:

- 1 – single measurement
- 2 – 2 consecutive measurements
- 3 – 4 consecutive measurements
- 4 – 8 consecutive measurements
- 5 – 16 consecutive measurements

*** The bigger is the value of the parameter, the deeper is the filter.

Tuning of the configurating word:

Bit 7

x	6	4	3	2	1	6	8	4	2	1
---	---	---	---	---	---	---	---	---	---	---

 Bit 0

Bit 0 – Operating mode of output K3

0 – Operating mode 0, 1- Operating mode 1

Bit 1 – Operating mode “Automatic start”

0 – Forbidden, 1 – Permitted

Bit 2 – Hiding of the menu “Call”

0 – Forbidden, 1 – Permitted

Bit 3 – Operating mode “Freezing” – Indicating of the last dosed weight on the screen till you press any button or „Start“. The operating mode is connected with the parameter **tEnd** - in case, that tEnd=0 “Freezing” is not active. 0 – Forbidden, 1 – Permitted

Bit 4 – Operating mode automatic tare – at start the instrument is tared, if the weight is in the admittance “StrtEn”. After the end of the dosing the operating correction of the tare is removed and you pass to the last manually set-pointed tare by the button for taring.

0 – Forbidden, 1 – Permitted

Bit 5 – method of dosing. At memorizing 0 the outputs for rough and fine dosing are switched on consecutively: **K1** -> **K2** .

In case of memorized 1, at rough dosing the outputs work together till the weight “ChAnGE” is reached, and then only the output for fine dosing leaves: **K1, K2 -> K2**.

Bit 6 – Start conditions for the filter after the time **t On** is up. If you memorize 1, the filter is not reset, i.e. the measurement is realized regardless of probable interferences as a result of the end of the previous dosing, the pouring of material or other transient events.

At memorizing of 0 the start conditions depend on that if the time **t On** is defined. If the **t On > 0** the filter is reset at every new start, and if the **t On = 0** – no.

Every bit in the configuration word has its weight value, and the configuration word is memorized as a sum of the weight values.

Example: Mode 0, Automatic start – permitted and menu “Call” – permitted = 0 + 2 + 0 = 2

The change of these values must be realized with great attention. Once the access is activated, it is possible till the switching off of the power supply.

After the exit from this mode, till the first pressing of the button TARE, the controller measures the absolute weight (the tare is reset).

Bulgaria, 4000, Plovdiv, 57, Trakia, str.

Tel.: (+359 32) 642 519, 640 446 Fax: (+359 32) 640 446

www.microsyst.net e-mail: info@microsyst.net